



CATALOG NUMBER:	
JOB NAME:	
CUSTOMER NAME:	
NOTES:	TYPE:
	DATE:

FEATURES AND SPECIFICATIONS

WALL LIGHTING
WLM13 SERIES
13" DIE CAST WALL LIGHT

Wattages:

- Pulse Start: 70w - 150w ⓔ
- High Pressure Sodium: 70w - 150w
- Fluorescent: 52w - 84w

Construction:

- Die Cast Aluminum Housing
- Threaded Apertures for Conduit & Photo Control
- Face Frame Opens to the Side
- Emergency Battery Backup Available

Optics:

- Borosilicate Glass Lens

Electrical:

- UL Listed for Wet Locations

Specifications:

- Overall height: 9.02" (22.91 cm)
- Width: 14.2" (36.06 cm)
- Weight: 18 lbs / 8.16 kg.



ACCESSORIES

- 280-019-1 Wireguard for WLM
- 280-022-1 Polycarbonate Guard for WLM
- 320-013 Full Cut-Off Shield for WLM-Bronze
- 210-007 WLM Face Frame Assembly-Bronze
- 230-002 Button 120V Photo Control
- 230-008 Button 208-277V Photo Control

ORDERING INFORMATION

Order accessories as separate catalog numbers (shipped separately).

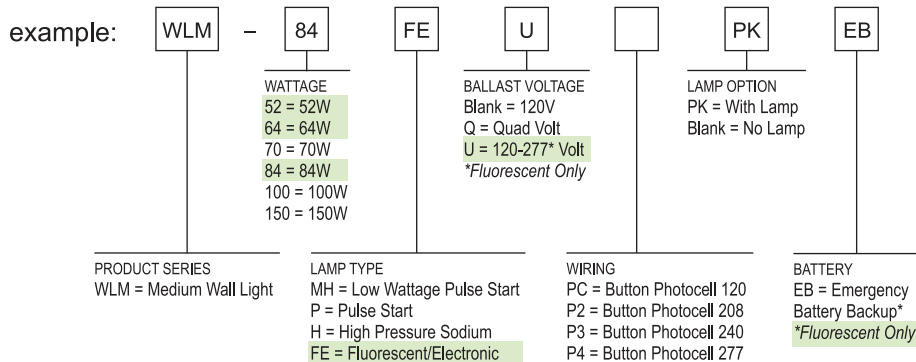

Actual performance can vary depending on operating conditions. Specifications are subject to change without notice.

DIMENSIONS

Specifications:

Overall height:
9.02" (22.91 cm)

Width:
14.2" (36.06 cm)

Weight:
18 lbs. / 8.16 kg.

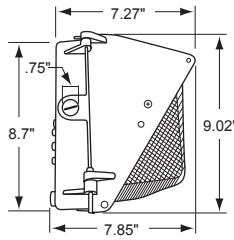
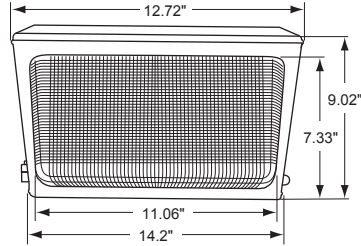

PHOTOMETRICS

150W PS @ 15' Mounting Height

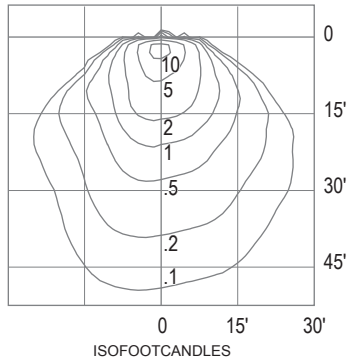

MOUNTING DETAILS

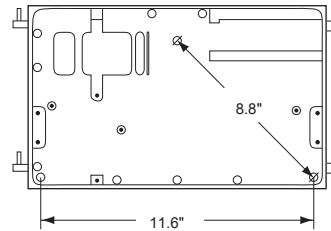

Actual performance can vary depending on operating conditions. Specifications are subject to change without notice.

ATLAS LIGHTING PRODUCTS, INC.

PO BOX 2348 | BURLINGTON, NC 27216

800-849-8485 | FAX: 336-227-0110 | www.atlaslightingproducts.com