



Universal Bracket System Angled Bracket

PROJECT INFORMATION

JOB NAME	
FIXTURE TYPE	Angled Bracket
CATALOG NUMBER	500-AAB
APPROVED BY	

SPECIFICATIONS

Construction:

- Aluminum
- Fits 2 3/8" Tenon
- Works with 16" and 22" SLP housings

Overall Height:

- 7.03" (17.85 cm)

Overall Width:

- 5.88" (14.94 cm)

Overall Depth:

- 3.00" (7.62 cm)

Warranty:

- Five-year limited warranty



BUY AMERICAN



COMPLIANT*

DIMENSIONS

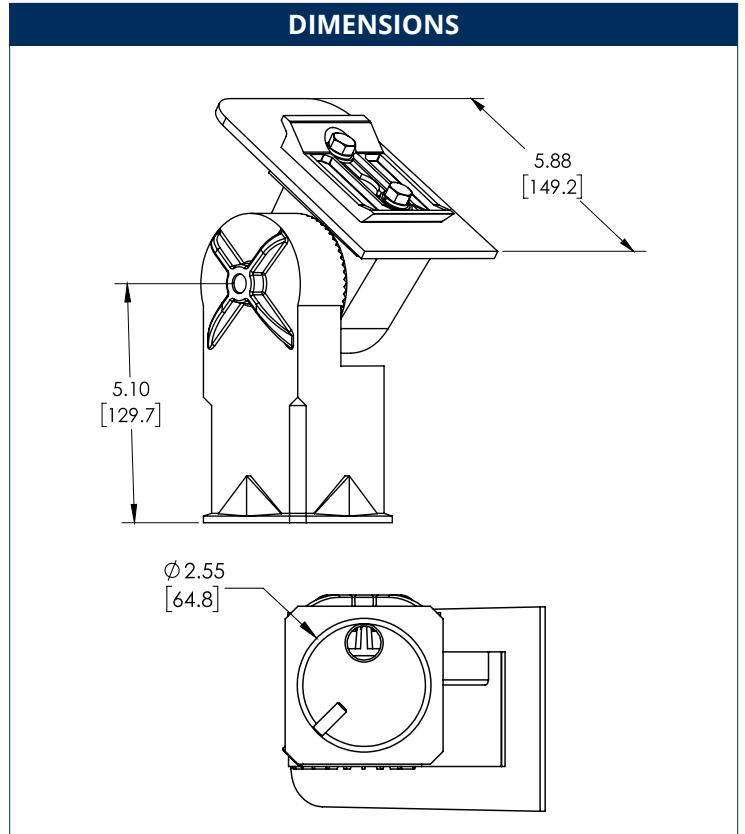

ORDERING INFORMATION

CATALOG #	DESCRIPTION	FINISH
500-AAB	Angled Bracket for SLP	Bronze
500-AABWT	Angled Bracket for SLP	White
500-AABBK	Angled Bracket for SLP	Black
500-AABSL	Angled Bracket for SLP	Silver