

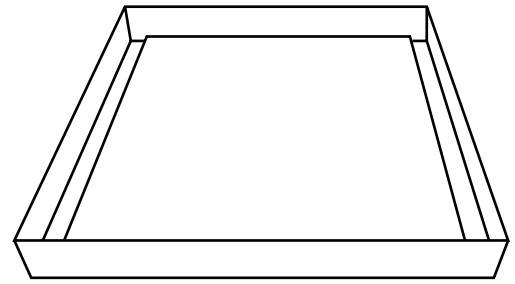

**Troffer/Panel**  
Surface Mount Kit



**PROJECT INFORMATION**

JOB NAME	
FIXTURE TYPE	Surface Mount Kit
CATALOG NUMBER	SMKFA
APPROVED BY	

**SPECIFICATIONS**

**Construction:**

- Extruded Aluminum
- White color finished

**DIMENSIONS**

SMKFA1X4

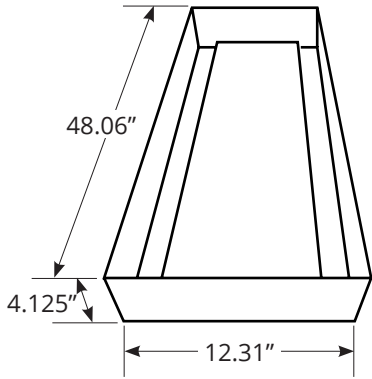

SMKFA2X2

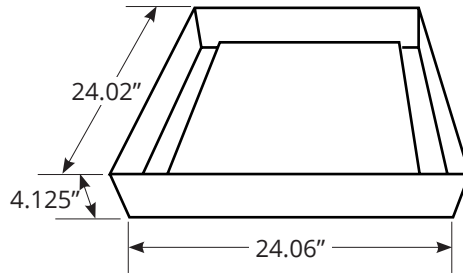

SMKFA2X4

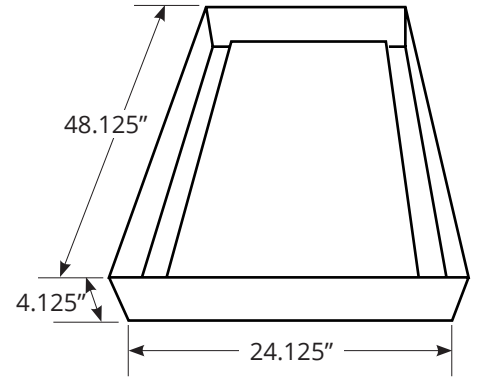

**ORDERING INFORMATION**

CATALOG #	DESCRIPTION	DIMENSIONS
SMKFA1x4	Surface Mount Kit for 1'x4' Panels and Troffer	12.31" x 48.06" x 4.125"
SMKFA2x2	Surface Mount Kit for 2'x2' Panels and Troffer	24.06" x 24.02" x 4.125"
SMKFA2x4	Surface Mount Kit for 2'x4' Panels and Troffer	24.125" x 48.125" x 4.125"