



# Universal Bracket System 15° Bracket



## PROJECT INFORMATION

JOB NAME	
FIXTURE TYPE	15° Bracket
CATALOG NUMBER	
APPROVED BY	

## SPECIFICATIONS

### Construction:

- Die Cast Aluminum

### Mounting:

- Allows you to seamlessly integrate SLPM Luminaires onto existing/ new construction square and round poles with (2) mounting hole spaces between 2.4" to 4.6".
- Rugged, thick gauge steel plates with (1) fixed and (1) adjustable nut and mounting hardware.

### Weight:

- 6.0 lbs. / 2.72 kg.

### Overall Height:

- 8.0" (20.32 cm)

### Overall Width:

- 3.9" (9.906 cm)

### Warranty:

- Five-year limited warranty



## DIMENSIONS

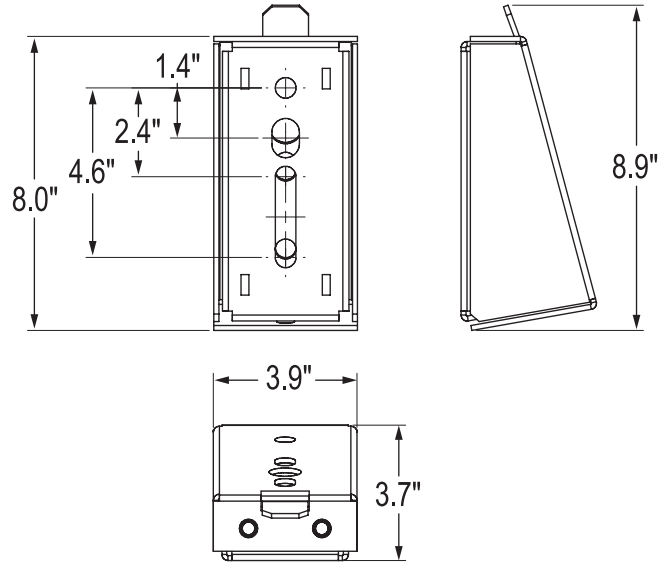

## ORDERING INFORMATION

CATALOG #	DESCRIPTION	FINISH
500-15BSQBZ	15° Bracket	Bronze
500-15BSQWT	15° Bracket	White